

# EXPLORER™ G2D 210-15



**3150**  
210 BAR  
**PSI**

**15**  
**L/PM**

**KOHLER KD15 - 440**  
**DIESEL**  
**ENGINE TYPE**  
KOHLER Diesel

**GEARBOX**  
**1450RPM**  
**DRIVE**

**HOT**  
**WATER**  
**OUTPUT**

## HERO INNOVATIONS

- TLL™**  
Top Lifting Lugs
- PEXO™**  
Stainless Steel Exoskeleton
- JWPP™**  
Jetwave UDOR™ Italian Premium Pump
- CC™**  
Centralised Control
- AVPS™**  
Anti Vibration Protection System
- MC™**  
Multi Configuration

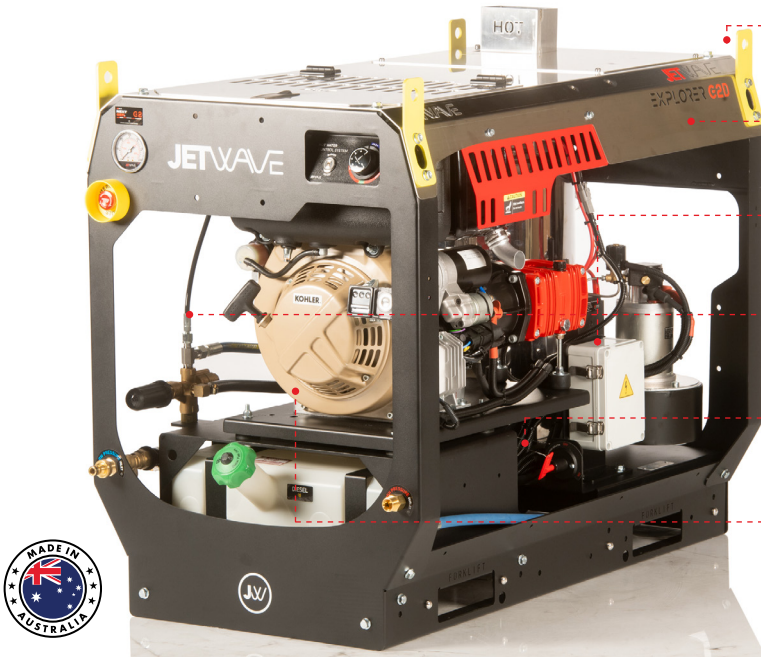

Registered Design © 202215869

## APPLICATIONS

- Tradesmen
- Construction/Earth Moving
- Mine Sites
- Hire & Rental

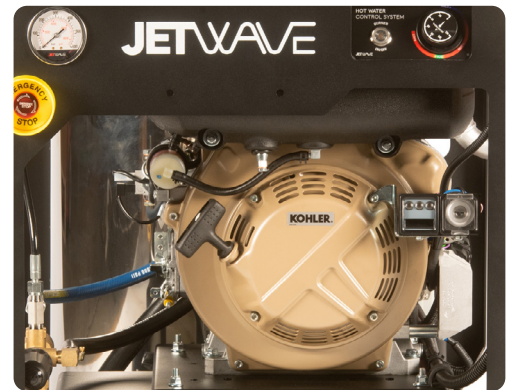
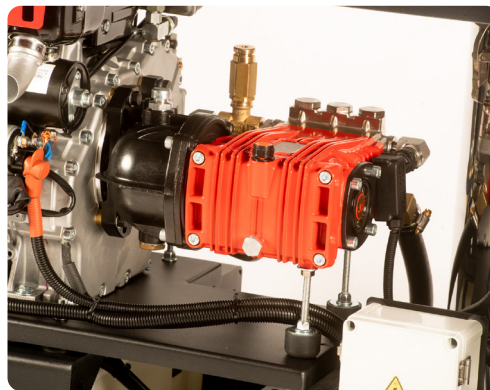

## STANDOUT FEATURES

- JW® UDOR® Premium Italian plunger pump** running at 1450RPM, delivers more performance and longer life.
- Industrial Kohler™ KD15-440 series air cooled engine**, with cyclonic air pre filter and twin fuel filtration for increased reliability.
- Jetwave Safety System™ (JSS)** thermal and safety valve to prevent overheating in excessive bypass and over pressurisation.
- Zero line pressure brass adjustable unloader valve.**
- Vertical burner with GeniSys™ 12v Advanced Burner Control** with smart sensors and protective features.
- Battery isolator & Emergency stop** for increased safety and longevity.

## STANDARD EQUIPMENT



**Gun:** J5500k low trigger force gun w/swivel & lance coupling system.

**Lance:** JW Straight stainless steel lance w/ snap coupling + nozzle w/protector & tail



**Hose:** 15m non marking double wire braid hose w/M22 couplings



**Chemical:** JW easy foam kit w/1L bottle



G2 WASHBOX VIDEO

## DIMENSIONS (MM)

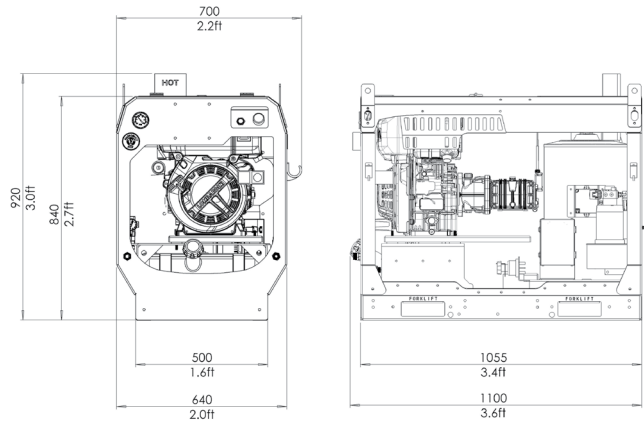

## TECHNICAL DATA

## EXPLORER G2D 210-15

Product Code	HW3000-15DG2
Pressure / Flow Rate	3150 (210 BAR) / 15 L/PM (900 L/PH) / 4 GPM
Max Water Inlet / Outlet Temp	60°C / 90°C
Class (AS/NZS: 4223)	A (3,150 Bar/Litres)
Usage Frequency	Professional: Daily Usage
Nozzle Size	O45
Frame Structure	CNC Modular skid galvanised steel chassis plus satin powder coat finish and <b>stainless steel cover</b>

## MOTOR FEATURES

Engine / Power	Kohler™ KD15-440 Electric Key Start (air cooled) 10HP / 441cc
Fuel Type / Capacity / Protection	Diesel / 3.4L / Low Oil Shutdown

## HYDRAULIC FEATURES

Pump / Head / Pistons	JW® UDOR® Premium Triplex Plunger / Brass (Nickle Plated) / Ceramic
Motor Pump Coupling / Pump RPM	Gearbox Drive / 1450RPM
Unloader Valve	Independent (Zero) - Adjustable
Safety Valve	Yes

## THERMAL FEATURES

Burner Model	Vertical 12v V Series
Fuel Supply / Capacity / Consumption	Diesel / 20L / 5.74 L/PH
Coil / Housing Material	Mild steel 3mm wall <b>seamless</b> (400BAR rated) / Stainless Steel

## DIMENSIONS & WEIGHT

Machine Dimensions / Weight	1100mm(L) x 700mm(W) x 920mm(H) / 280KG (approx.)
-----------------------------	---

## WARRANTY(S)

Unit / Pump Warranty*	 2 Years
Engine Warranty*	<b>KOHLER</b> Diesel 3 Years

## OPTIONAL ACCESSORIES

## OPTIONAL UPGRADES

30m Hose Reel w/30m of hose	1060CMPL-EXPD30M	Engine Hour Metre	ACD-TACHO
60m Hose Reel w/60m of hose	1067CMPL EXPD60M	4 Wheel Trolley Kit A (4xOffroad Wheels)	JWA407
JW Bypass Pro Foam	PROFOAM	4 Wheel Trolley Kit B (2xCastor Wheels 2xOffroad Wheels)	JWA407E
JW Pro Turbo Head	JWA1303.045	Hose Reel Roller Guide HGS™	1067-GUIDEASSY
21" Hammerhead - ABS Plastic	JWA-FSC21	Mine Specification Kit	G2DMINESPEC-B
21" Hammerhead - Stainless Steel	JWA-FSC21-5		

Copyright © 2023 Jetwave® Group Pty Ltd. All Rights Reserved.

The manufacturer reserves the right to modify design features and technical facts without notice, due to our principals of continuous improvement.

\*Coverage against defects in material and workmanship (refer to Jetwave's and component partners T&Cs).

V3.0 08/23