

HORNET™ G2 QXE 280-15



4060
280 BAR
PSI

15
L/PM

HONDA GX390
PETROL
ENGINE TYPE
POWERED by HONDA

GEARBOX
1450RPM
DRIVE

COLD WATER
OUTPUT



HERO INNOVATIONS



PEXO™
Stainless Steel Exoskeleton



JWPP™
Jetwave Italian Premium Pump



CC™
Centralised Control



AVPS™
Anti Vibration Protection System



MC™
Multi Configuration



Registered Design © 202215870

APPLICATIONS



Tradesmen



Commercial & Exterior Cleaning



Agriculturist



Construction

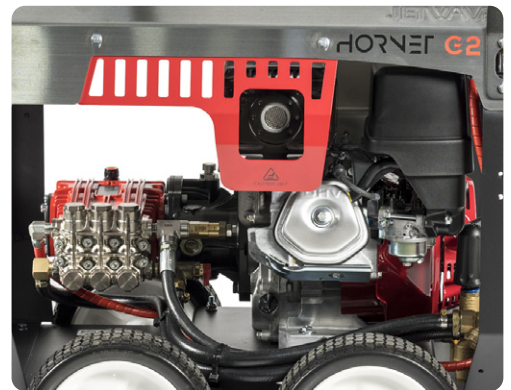

STANDOUT FEATURES



JW® UDOR® Premium Italian plunger pump running at 1450RPM, delivers more performance and longer life.



Honda™ QXE GX390 Industrial Series Engine with with **electric key start** (back up pull start).



Jetwave Safety System™ (JSS) thermal and safety valve to prevent overheating in excessive bypass and over pressurisation.



Heavy duty JW Premium brass adjustable unloader valve. With flat spring design for longevity.



Battery isolator to prevent battery voltage loss, when not in use.



Emergency stop for increased operator safety.

STANDARD EQUIPMENT



Gun: J5500k low trigger force gun w/swivel & lance coupling system.

Lance: JW Straight stainless steel lance w/ snap coupling + nozzle w/protector & tail



Hose: 10m non marking double wire braid hose w/M22 couplings

DIMENSIONS (MM)

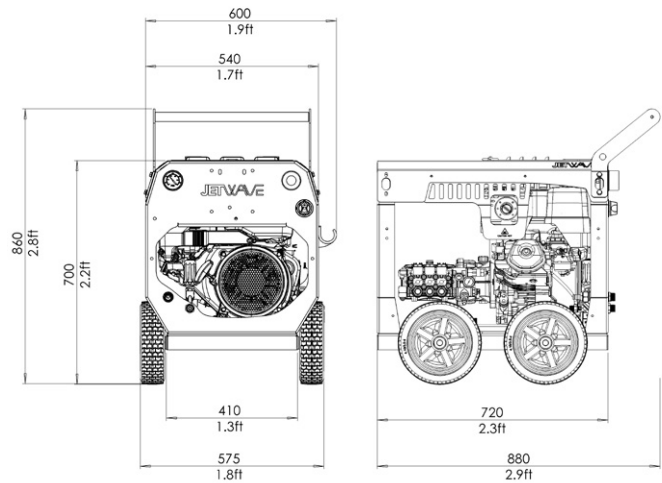

TECHNICAL DATA

HORNET™ QXE 280-15

Product Code	CW4000-15PEG2
Pressure / Flow Rate	4060PSI (280 BAR) / 15 L/PM (900 L/PH) / 4 GPM
Max Water Inlet Temp	50°C/ 122°F
Class (AS/NZS: 4223)	A (4,200 Bar/Litres)
Usage Frequency	Professional: Daily
Nozzle Size	04
Frame Structure	CNC Modular galvanised sheet steel chassis plus satin powder coat finish and stainless steel cover

MOTOR FEATURES

Engine / Power	Honda™ GX390 QXE Electric Start (air cooled) 13HP / 390cc
Fuel Type / Capacity / Protection	Unleaded / 6.1L / Low Oil Shutdown

HYDRAULIC FEATURES

Pump / Head / Pistons	JW® UDOR® Premium Triplex Plunger / Brass (Nickle Plated) / Ceramic
Motor Pump Coupling / Pump RPM	Gearbox Drive / 1450RPM
Unloader Valve	Independent - Adjustable (Panel Mounted)
Safety Valve	Yes

DIMENSIONS & WEIGHT

Machine Dimensions / Weight	880mm(L) x 575mm(W) x 860mm(H) / 90KG (approx.)
-----------------------------	---

WARRANTY(S)

Unit / Pump Warranty*	 2 Year(s)
Engine Warranty*	 3 Year(s)

OPTIONAL ACCESSORIES

OPTIONAL UPGRADES

30m Hose Reel	1060CMPL-H30M	Wheel Brake System Kit	JWA-WBS
JW Pro Turbo Head	JWA303-04	Engine Hour Meter	TACHHOUR8075
21" Hammerhead FSC - Stainless Steel	JWA-FSC22-5.04		
JW Easy Foam Kit	JW73.1		

Copyright © 2024 Jetwave® Group Pty Ltd. All Rights Reserved.

The manufacturer reserves the right to modify design features and technical facts without notice, due to our principals of continuous improvement.
*Coverage against defects in material and workmanship (refer to Jetwave's and component partners T&Cs).

V4.0 07/24