

RAPTOR™ G2



4000
275 BAR
PSI

15
L/PM

HONDA GX390
PETROL
ENGINE TYPE
POWERED BY
HONDA.

DIRECT
3400RPM
DRIVE

COLD
WATER
OUTPUT



HERO INNOVATIONS



PEXO™
Stainless Steel Exoskeleton



TLL™
Top Lifting Lug



AFW™
Anti Flat Wheels



AVPS™
Anti Vibration Protection System



JWPP™
Jetwave™ AR® Premium Pump

Registered Design ® 202215871

APPLICATIONS



Agriculturist



Light Exterior Cleaning



Light Work Tradesmen



Light Work Commercial Cleaners



STANDOUT FEATURES



JW® Premium AR® triplex pump delivers better performance and longevity.



Industrial Honda™ GX390 pull start series engine that delivers performance and reliability.



Jetwave Safety System™ (JSS) thermal and safety valve to prevent overheating in excessive bypass and over pressurisation.



Soft grip handle ergonomic and compact.



DIY water filter and tie down points for a secure transportation.



Tool free dual M22 screw hose coupling system.

STANDARD EQUIPMENT



Gun/Lance: J5000™ High Pressure Gun w/swivel + lance w/variable pressure control.



Hose: 10m non marking double wire braid hose w/M22 couplings.



Chemical: In-line chemical downstream injector w/strainer.

DIMENSIONS (MM)

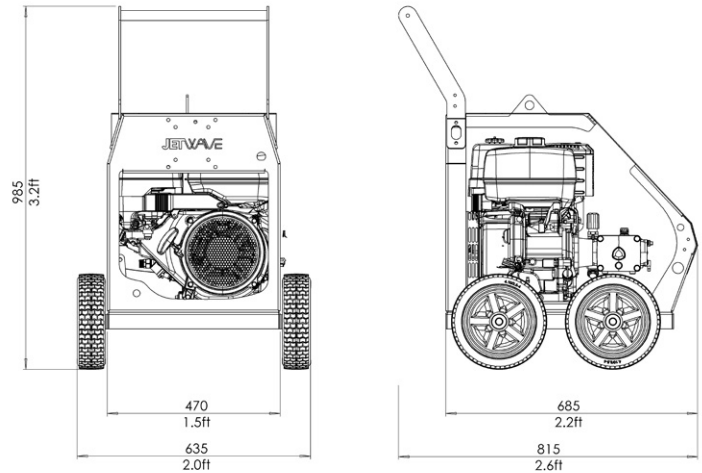

TECHNICAL DATA 0:00

RAPTOR™ G2

Product Code	CW4000-15P
Pressure / Flow Rate	4000PSI (275 BAR) / 15 L/PM (900 L/PH) / 4 GPM
Max Inlet Temp	50°C / 122°F
Class (AS/NZS: 4223)	A (4.125 Bar/Litres)
Usage Frequency	Semi Professional: Weekly
Nozzle Size	035
Frame Structure	CNC Modular galvanised steel chassis plus satin powder coat finish and stainless steel cover

MOTOR FEATURES

Engine / Power	Honda™ GX390 Pull Start (air cooled) 13HP / 390cc
Fuel Type / Capacity / Protection	Unleaded / 6.1L / Low Oil Shutdown

HYDRAULIC FEATURES

Pump / Head / Pistons	JW® AR® Triplex Plunger / Brass (Nickle Plated) / Ceramic
Motor Pump Coupling / Pump RPM	Direct Drive / 3400RPM
Unloader Valve	Banjo Bolt on
Safety Valve	Yes
Detergent Injector	Yes - Downstream low pressure

DIMENSIONS & WEIGHT

Machine Dimensions / Weight	815mm(L) x 635mm(W) x 985mm(H) / 80KG (approx.)
-----------------------------	---

WARRANTY(S)

Unit / Pump Warranty*	2 Years
Engine Warranty*	3 Years

OPTIONAL ACCESSORIES

30m Hose Reel w/30m Hose	1060CMPL-RAP30
JW12 Foaming Lance w/1L Tank	JWA221-LS12
Turbo Head w/Lance	JWA160.04
21" Hammerhead - Plastic	JWA-FSC21.04

Copyright © 2024 Jetwave® Group Pty Ltd. All Rights Reserved.

The manufacturer reserves the right to modify design features and technical facts without notice, due to our principals of continuous improvement.
*Coverage against defects in material and workmanship (refer to Jetwave's and component partners T&Cs).

V4.0 07/24